



## HD25A Features

- NEMA size 25 package
- Anodized milled aluminum housing with O-ring housing seal
- 3/8 in. diameter shaft
- Up to 15 devices on a single 6-pin telephone-type cable
- 12-bit resolution
- 7 milliseconds update time
- EEPROM stores downloadable parameters
- Field programmable resolution (2 to 4,096 CPR)
- Remotely updatable firmware

## HD25A Product Description

The HD25A is a NEMA 25 sized absolute encoder designed for industrial applications. The HD25A optical encoder is a 12-bit absolute rotary position sensor, which reports a shaft angle within a single 360-degree rotation of a shaft. Unlike incremental, sometimes called relative style encoders, the HD25A provides true (absolute) shaft position, eliminating the need for a home or zero cycle after a supply voltage power cycle.



The HD25A communicates over a RS 485-style serial bus utilizing US Digital's SEI (Serial Encoder Interface) which allows for simple, quick, and convenient networking of multiple SEI devices on a single network. PLCs, motion controllers, and computers can also reside on the SEI bus as well by use of US Digital's SEI to USB interface device. For complete information about the SEI bus please refer to the SEI Communications Protocol (<https://www.usdigital.com/support/resources/reference/user-guides/sei-absolute-encoder-communications-protocol/>) webpage.

The HD25A also provides an analog output. The analog output provides a maximum voltage range of 0 to 4.095 volts with 12-bit resolution. The output voltage can be scaled by simple SEI commands to provide user-defined voltage ranges. From the factory, the analog output voltage is set to 0 to 3.599 VDC range.



# Mechanical Drawings

### HD25A Industrial Absolute Shaft Encoder

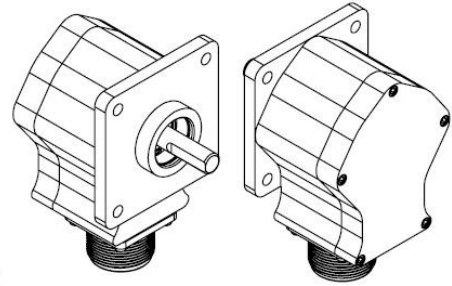

RELEASE DATE: 7/12/2017

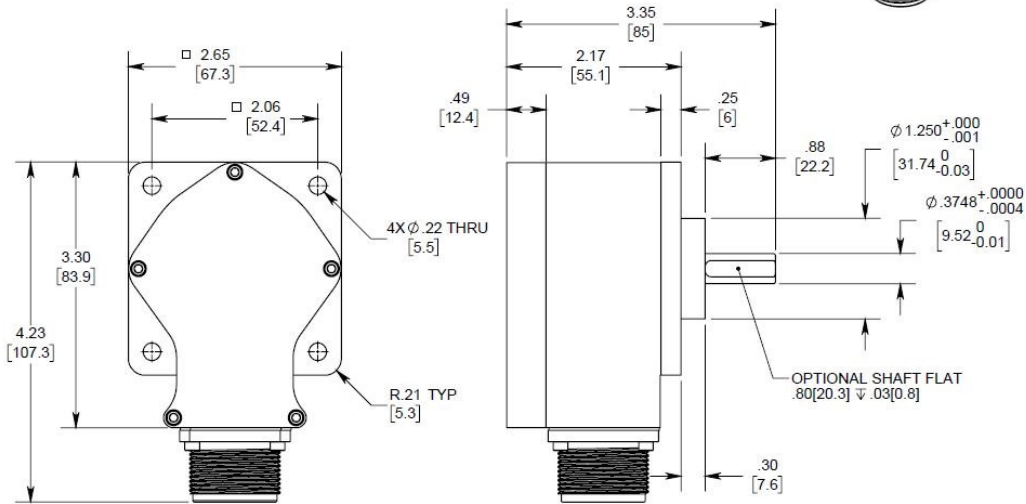

**US DIGITAL** 1400 NE 136th Avenue  
Vancouver, Washington 98684, USA

info@usdigital.com  
www.usdigital.com

Local: 360.260.2468  
Toll-free: 800.736.0194

UNITS: INCHES [MM]  
METRIC SHOWN FOR REFERENCE ONLY

# Specifications

## ENVIRONMENTAL

Parameter	Value	Units
Operating Temperature	-25C to 70C	C
Vibration (5 to 2kHz)	20	G
Shock, 11 mSec	60	G
Electrostatic Discharge, IEC 61000-4-2	± 4	kV



1400 NE 136th Ave.  
Vancouver, WA 98684  
USA

info@usdigital.com  
sales@usdigital.com  
support@usdigital.com

Toll Free: **800.736.0194**  
Worldwide: **360.260.2468**  
Support: **360.397.9999**

**MECHANICAL**

Parameter	Value
Size	NEMA 25
Housing and Cover Material	Anodized aluminum
Weight	16.91 oz.
Shaft Material	Stainless steel
Shaft Diameter	0.3748 in. (+0.0000 in. -0.0004 in.)
Shaft Optional Flat Size	0.80 in. long x 0.03 in. deep
Max. Acceleration	100000 rev / sec <sup>2</sup>
Max. Shaft Speed Non-sealed (mechanical) Sealed (mechanical)	15000 RPM 6000 RPM
Max. Shaft Torque Non-sealed Sealed	< 0.5 in-oz 3.5 in-oz typical
Max. Shaft Load Axial Radial	40 lb. 35 lb.
Max. Shaft Runout	0.0003 in. T.I.R.
Bearing Life @ 4 Pound Load	2.3 x 10 <sup>9</sup> revolutions
Moment of Inertia	2.8 x 10 <sup>-4</sup> oz-in-sec <sup>2</sup>
Technical Bulletin TB1001 - Shaft and Bore Tolerances	Download ( <a href="https://www.usdigital.com/support/resources/reference/technical-docs/technical-bulletins/shaft-and-bore-tolerances-tb1001/">https://www.usdigital.com/support/resources/reference/technical-docs/technical-bulletins/shaft-and-bore-tolerances-tb1001/</a> )



## ELECTRICAL

- Specifications apply over entire operating temperature range.
- Typical values are specified at Vcc = 12V and 25C.

Parameter	Min.	Typ.	Max.	Units
Supply Voltage	7.5	12	16	V
Supply Current				
Active		14	18.5	mA
Sleep			2.5	
Analog Output Impedance		51		Ohms
Zero Scale Analog Voltage	0	2	12	mV
Full Scale Analog Voltage	4.066	4.095	4.124	V
Output Noise (Analog version)		10		mV rms
Differential Nonlinearity	-1.0		1.0	LSB
Absolute Accuracy (SEI interface version)		0.18	0.25	Degrees
Angle tracking speed				
Single-turn mode			3600	RPM
Multi-turn mode			1800	
Position Update Rate (1)			7	msec.

(1) The internal microcontroller takes a snapshot of the disk every 7 msec. and stores the position in memory. It responds immediately to a "report position request" by sending the most recently computed position.

## DEFAULT SETTINGS

Parameter	Default value	Volatile?
SEI address	0	Non-volatile
Resolution	3600	Non-volatile
Origin offset	0	Non-volatile
Baud rate	9600	Volatile
Mode	0	(1)

(1) Mode is always restored from non-volatile EEPROM on power-up; however, there are separate SEI commands for setting the RAM copy only, or both the RAM copy and the non-volatile EEPROM copy. For an explanation of the Mode bits see SEI Absolute Encoder Communications Protocol (<https://www.usdigital.com/support/resources/reference/user-guides/sei-absolute-encoder-communications-protocol/>).



### SEI NETWORK

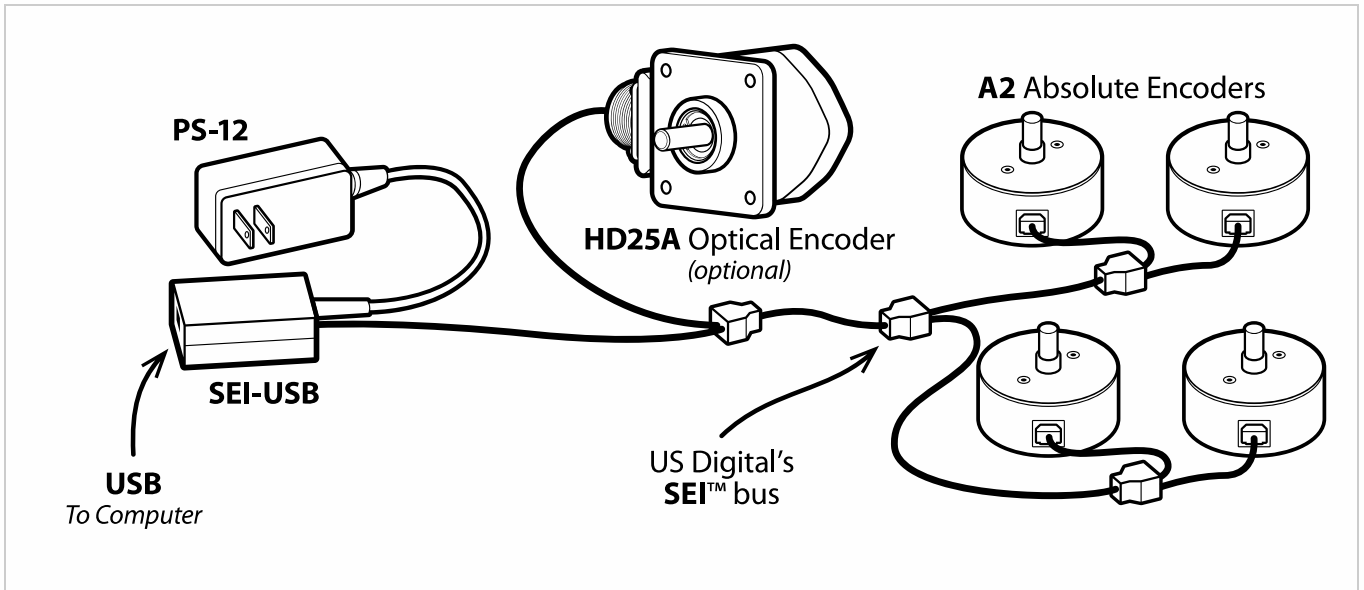

### ANALOG OUTPUT

### PIN-OUTS

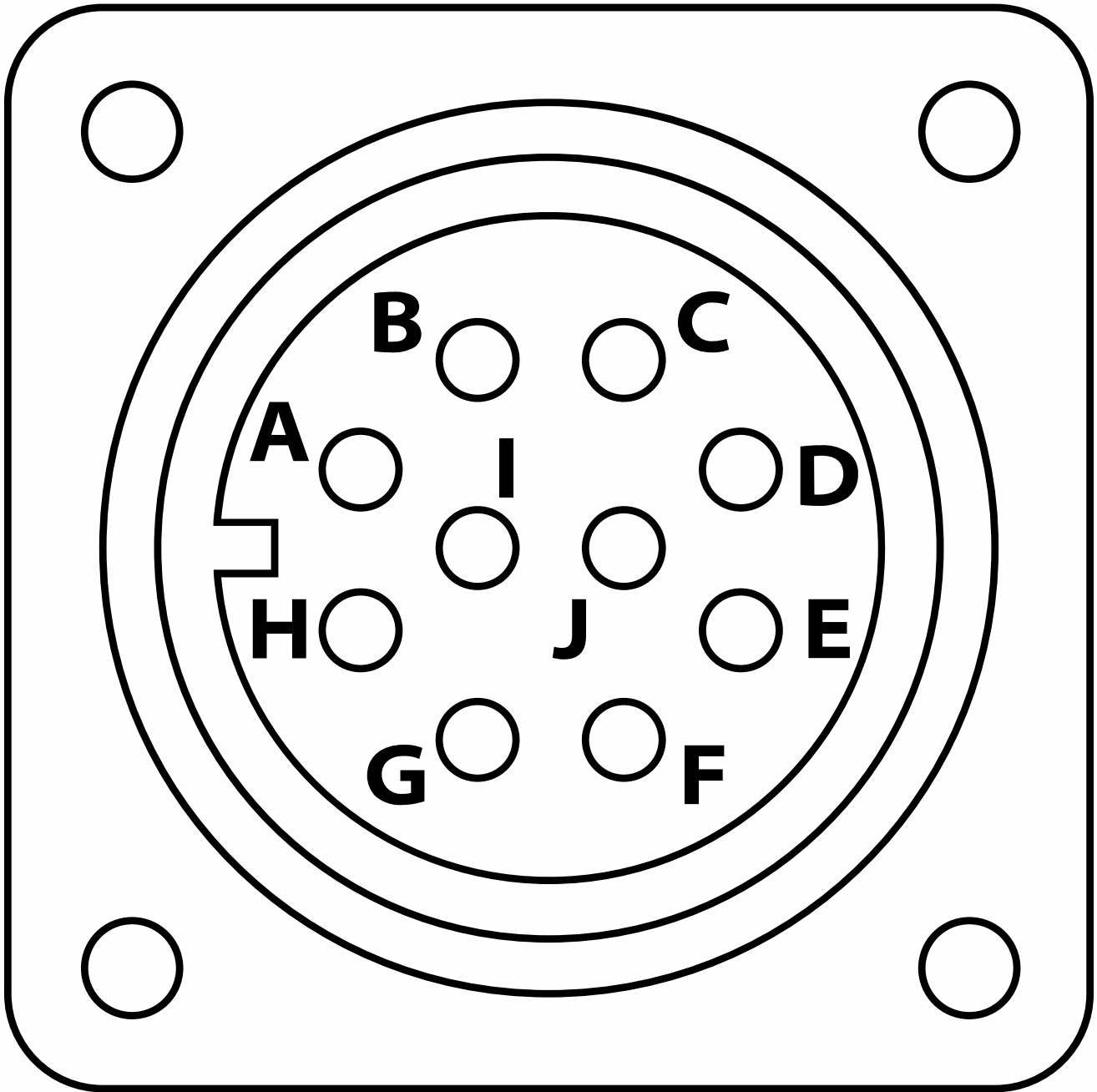



PIN	DESCRIPTION
A	Data H
B	Busy+
C	Analog+
D	Power
E	NC
F	Ground
G	Case Ground
H	Data L
I	Busy-
J	Analog-

### Notes

- Cables and connectors are not included and must be ordered separately.
- US Digital® warrants its products against defects in materials and workmanship for two years. See complete warranty (<https://www.usdigital.com/company/warranty>) for details.

### Configuration Options

<b>HD25A</b>	-	<b>Shaft Type</b>	-	<b>Shaft Seal</b>
		N (Shaft without Flat)		N (Non-Sealed)
		F (Shaft with Flat)		S (Sealed)

**PLEASE NOTE: This chart is for informational use only.** Certain product configuration combinations are not available. Visit the HD25A product page (<https://www.usdigital.com/products/HD25A>) for pricing and additional information.