

MAE4 Assembly Instructions

Please Note: The MAE4 is recommended for use as a one-time installation.

Step 1:

Slip push-on magnetic hub over shaft and firmly press down until top of shaft fills cavity of hub.

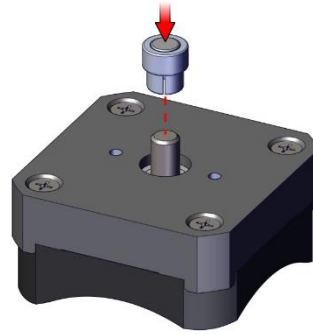

Step 2:

Place encoder body over shaft assembly so that it sits on mounting surface.

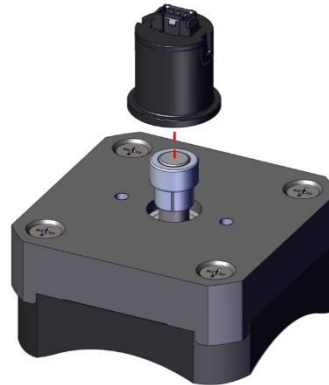

Step 3:

With recess in base facing towards mounting surface, place base over encoder body so that flange of body fits into recess of base.

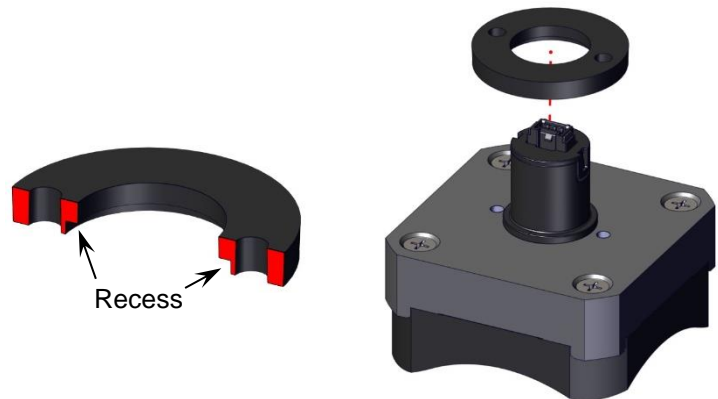

Step 4:

Secure base to mounting surface with two screws (#4 recommended, sold separately).

Zero positioning: Prior to fully tightening screws, encoder can be powered and rotated by hand to set absolute zero position, if desired.

